

Cilindri compatti iso 21287 / Compact Cylinders iso 21287

I nuovi cilindri compatti a normativa ISO 21287 sono stati realizzati con alesaggi da 20 mm a 100 mm e hanno un ingombro inferiore del 50% rispetto ad un cilindro ISO 15552 di misure equivalenti.

Il grande vantaggio di questi cilindri è l'interfaccia ISO che permette l'abbinamento con i medesimi dispositivi di fissaggio dei cilindri ISO 15552 (ISO 6431 VDMA 24562)

I cilindri ISO 21287 hanno un design pulito ed elegante. Il tubo è dotato di cave longitudinali su tre lati per l'inserimento a scomparsa dei sensori magnetici. Sono inoltre presenti paracolpi elastici a fine corsa.

È disponibile anche la versione con stelo filetto maschio.

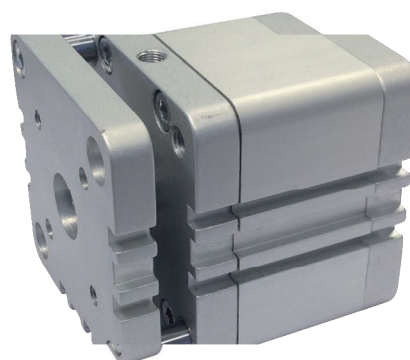

The new compact cylinders normative ISO 21287 have been manufactured with bores from 20 mm up to 100 mm and they are 50% smaller compared to ISO 15552 cylinders with equivalent dimension.

The biggest advantage of these cylinders is the ISO interface that permits the combination with the same mounting accessories of ISO 15552 (ISO 6431 VDMA 24562) cylinders.

ISO 21287 cylinders have a clean and elegant design. The tube has longitudinal slots on three sides for the total insertion of magnetic switches. There are also elastic bumpers at the stroke end.

It is also available a version with male thread piston rod.

Caratteristiche Tecniche / Technical Characteristics

Pressioni / Pressures

Pressione minima / Minimum pressure: **1 bar** (0.1 MPa)
Pressione massima / Maximum pressure: **10 bar** (1 MPa)

Temperature / Temperatures

Temperatura minima / Minimum temperature: 0 °C
(-20 °C con aria secca / with dry air)
Temperatura massima / Maximum temperature: +80 °C

Fluidi compatibili / Fluids

Aria compressa filtrata e lubrificata e non lubrificata.
Filtered and lubricated compressed air as well as non lubricated air.

Funzionamento / Functioning

Semplice effetto magnetico, Doppio effetto magnetico.
Stelo singolo, passante e Antirotazione.
Single and Double-acting magnetic.
Single, through piston rod and Antirotation.

Alesaggi / Bores

Da 20 a 100 mm / From 20 to 100 mm

Corse / Strokes

Corse Standard / Standard Strokes
Da 5 a 200 mm / From 5 to 200 mm

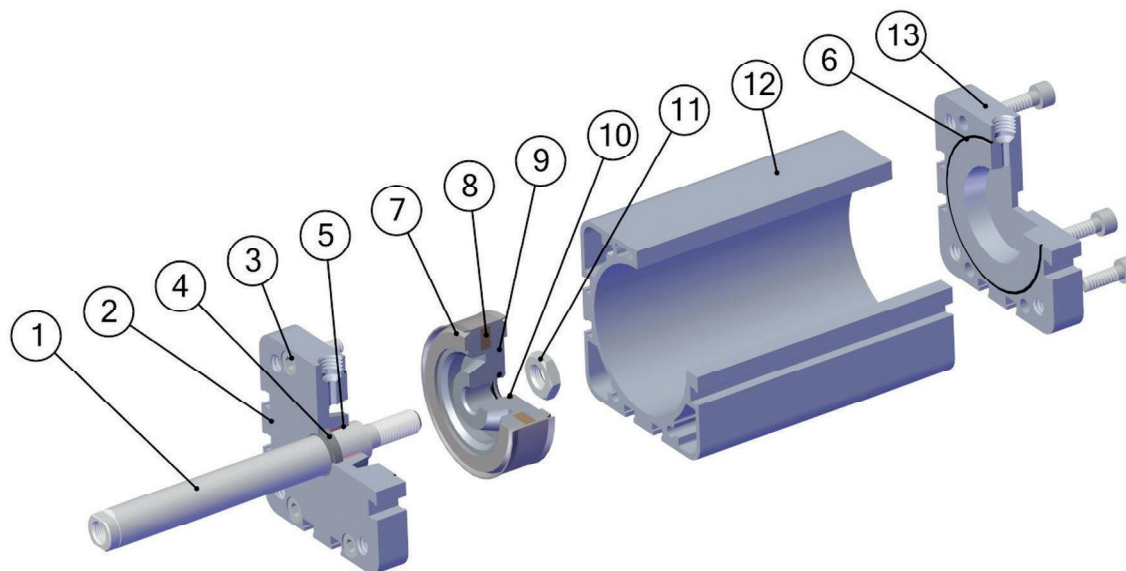
Caratteristiche Tecniche / Technical Characteristics

Materiali e Componenti / Component Parts and Materials

- | | | | |
|----|---|----|---|
| 1 | Asta pistone acciaio cromato
(AISI 303 da 20 a 25) (C40 da 32 a 100) | 1 | Chrome steel Piston rod
(AISI 303 from 20 to 25)(C40 from 32 to 100) |
| 2 | Testata anteriore in alluminio anodizzato | 2 | Anodised aluminium Front cover |
| 3 | Vite in acciaio zincato | 3 | Zinc-plated steel Screw |
| 4 | Guarnizione asta in poliuretano | 4 | Polyurethane Rod Seal |
| 5 | Bronzina in bronzo sinterizzato | 5 | Sintered bronze Bearing |
| 6 | Guarnizione O-RING in NBR | 6 | NBR O-RING Seals |
| 7 | Guarnizione pistone in poliuretano | 7 | Polyurethane Piston Seal |
| 8 | Magnete in plastoferrite | 8 | Bonded ferrite Magnet |
| 9 | Pistone in alluminio | 9 | Aluminium Piston |
| 10 | Guarnizione O-RING in NBR | 10 | NBR O-RING Seals |
| 11 | Dado fissaggio pistone in acciaio zincato | 11 | Zinc-plated steel Piston nut |
| 12 | Camicia cilindro in alluminio anodizzato | 12 | Anodised aluminium Cylinder shape body |
| 13 | Testata posteriore in alluminio anodizzato | 13 | Anodised aluminium Back cover |

Forze e Consumi / Forces And Consumptions

FORZE DI SPINTA E TIRO - THRUST AND TRACTION FORCES

Ø Cilindro Ø Cylinder	Ø Stelo Ø Rod	Superficie utile in mm2 Working Surface in mm2	Pressione di lavoro in bar Operating pressure in bar									
			1	2	3	4	5	6	7	8	9	10
			Forza sviluppata in N Output force in N									
Ø20	10	Spinta / Thrust = 314	28	55	85	110	140	170	195	220	250	280
		Trazione / Traction = 235	21	42	60	85	105	125	150	170	190	210
Ø25	10	Spinta / Thrust = 490	44	88	132	176	220	264	308	352	396	440
		Trazione / Traction = 412	36	72	108	144	180	216	252	288	324	360
Ø32	12	Spinta / Thrust = 804	72	144	216	288	360	432	504	576	648	720
		Trazione / Traction = 691	62	124	186	248	310	372	434	496	558	620
Ø40	12	Spinta / Thrust = 1257	110	220	330	440	550	660	770	880	990	1100
		Trazione / Traction = 1144	100	200	300	400	500	600	700	800	900	1000
Ø50	16	Spinta / Thrust = 1963	175	350	525	700	875	1050	1225	1400	1575	1750
		Trazione / Traction = 1762	155	310	465	620	775	930	1085	1240	1395	1550
Ø63	16	Spinta / Thrust = 3117	280	560	840	1120	1400	1680	1960	2240	2520	2800
		Trazione / Traction = 2916	260	520	780	1040	1300	1560	1820	2080	2340	2600
Ø80	20	Spinta / Thrust = 5027	450	900	1350	1800	2250	2700	3150	3600	4050	4500
		Trazione / Traction = 4712	420	840	1260	1680	2100	2520	2940	3360	3780	4200
Ø100	25	Spinta / Thrust = 7854	700	1400	2100	2800	3500	4200	4900	5650	6360	7000
		Trazione / Traction = 7363	660	1320	1980	2640	3300	3960	4620	5280	5940	6600

FORZE DELLA MOLLA - SPRING TRACTION FORCES

Ø Cilindri Ø Cylinder	Carico Molla Load Spring	Corsa / Stroke				
		5	10	15	20	25
		Forza sviluppata in N Output force in N				
Ø20	Carico Molla a Riposo / Load of spring at rest	15,7	14	12,2	10,4	8,7
	Carico Molla Compressa / Load of compressed spring	17,4	17,4	17,4	17,4	17,4
Ø25	Carico Molla a Riposo / Load of spring at rest	19,5	18,5	17,3	16	15
	Carico Molla Compressa / Load of compressed spring	22	22	22	22	22
Ø32	Carico Molla a Riposo / Load of spring at rest	27,8	25,3	22,8	20,2	17,7
	Carico Molla Compressa / Load of compressed spring	30	30	30	30	30
Ø40	Carico Molla a Riposo / Load of spring at rest	36,4	34	31,7	29,5	27
	Carico Molla Compressa / Load of compressed spring	36	36	36	36	36
Ø50	Carico Molla a Riposo / Load of spring at rest	32	30,5	29	27,8	26,5
	Carico Molla Compressa / Load of compressed spring	35	35	35	35	35
Ø63	Carico Molla a Riposo / Load of spring at rest	61	58,5	56,3	53,5	51,5
	Carico Molla Compressa / Load of compressed spring	64,8	64,8	64,8	64,8	64,8
Ø80	Carico Molla a Riposo / Load of spring at rest	91,3	88	85	82	78,7
	Carico Molla Compressa / Load of compressed spring	94	94	94	94	94
Ø100	Carico Molla a Riposo / Load of spring at rest	150	145	140	134	129
	Carico Molla Compressa / Load of compressed spring	156	156	156	156	156

CONSUMI CILINDRO - CYLINDER AIR CONSUMPTION

Ø Cilindro Ø Cylinder	Ø Stelo Ø Rod	Superficie utile in mm2 Working Surface in mm2	Pressione di lavoro in bar Operating pressure in bar									
			1	2	3	4	5	6	7	8	9	10
			Consumo aria in NL per ogni 10mm. di corsa Air consumption in NL for each 10mm. of stroke									
Ø20	10	Spinta / Thrust = 314	0,006	0,009	0,013	0,016	0,019	0,022	0,025	0,028	0,031	0,035
		Trazione / Traction = 235	0,005	0,007	0,009	0,012	0,014	0,016	0,019	0,021	0,024	0,026
Ø25	10	Spinta / Thrust = 490	0,010	0,015	0,020	0,025	0,029	0,034	0,039	0,044	0,049	0,054
		Trazione / Traction = 412	0,008	0,012	0,016	0,021	0,025	0,029	0,033	0,037	0,041	0,045
Ø32	12	Spinta / Thrust = 804	0,016	0,024	0,032	0,040	0,048	0,056	0,064	0,072	0,080	0,088
		Trazione / Traction = 691	0,014	0,021	0,028	0,035	0,041	0,048	0,055	0,062	0,069	0,076
Ø40	12	Spinta / Thrust = 1257	0,025	0,038	0,050	0,063	0,075	0,088	0,101	0,113	0,126	0,138
		Trazione / Traction = 1144	0,023	0,034	0,046	0,057	0,069	0,080	0,092	0,103	0,114	0,126
Ø50	16	Spinta / Thrust = 1963	0,039	0,059	0,079	0,098	0,118	0,137	0,157	0,177	0,196	0,216
		Trazione / Traction = 1762	0,035	0,053	0,070	0,088	0,106	0,123	0,141	0,159	0,176	0,194
Ø63	16	Spinta / Thrust = 3117	0,062	0,094	0,125	0,156	0,187	0,218	0,249	0,281	0,312	0,343
		Trazione / Traction = 2916	0,058	0,087	0,117	0,146	0,175	0,204	0,233	0,262	0,292	0,321
Ø80	20	Spinta / Thrust = 5027	0,101	0,151	0,201	0,251	0,302	0,352	0,402	0,452	0,503	0,553
		Trazione / Traction = 4712	0,094	0,141	0,188	0,236	0,283	0,330	0,377	0,424	0,471	0,518
Ø100	25	Spinta / Thrust = 7854	0,157	0,236	0,314	0,393	0,471	0,550	0,628	0,707	0,785	0,864
		Trazione / Traction = 7363	0,147	0,221	0,295	0,368	0,442	0,515	0,589	0,663	0,736	0,810

Tabella dei codici di ordinazione - Ordering codes

W	B	M	0 3 2	0 0 2 5
<p>Corsa mm. / Stroke mm. 5 - 10 - 15 - 20 - 25 - 30 - 40 - 50 - 60 - 80 - 100 - 125 - 150 - 160 - 200 A richiesta corse intermedie o superiori <i>Intermediate or higher strokes are available upon request.</i></p> <hr/> <p>Diametro mm. / Diameter mm. 20-25-32-40-50-63-80-100</p> <hr/> <p>Versioni / Version = Standard Stelo femmina / Standard female rod M= Stelo Maschio (No WFA) / Male rod (No WFA)</p> <hr/> <p>Esecuzione / Execution B= Semplice Effetto Magnetico - Single-Acting Magnetic D= Semplice Effetto Magnetico - Molla In Spinta - Single-Acting Magnetic - Spring Thrust F= Doppio Effetto Magnetico - Double Acting Magnetic J= Doppio Effetto Stelo Passante Magnetico - Double Acting Magnetic With Double Rod End FA= Doppio Effetto Magnetico Antirotazione - Double-Acting Magnetic Antirotation</p> <hr/> <p>W= Serie Compatto ISO 21287 / Compact ISO 21287</p>				

CORSE STANDARD mm. - STD STROKES

Ø mm.	5	10	15	20	25	30	40	50	60	80	100	125	150	200
20	▲●#	▲●#	▲●#	▲●#	▲●#	●#	●#	●#						
25	▲●#	▲●#	▲●#	▲●#	▲●#	●#	●#	●#						
32	▲●#	▲●#	▲●#	▲●#	▲●#	●#	●#	●#	●#	●#	●	●	●	
40	▲●#	▲●#	▲●#	▲●#	▲●#	●#	●#	●#	●#	●#	●	●	●	
50	▲●#	▲●#	▲●#	▲●#	▲●#	●#	●#	●#	●#	●#	●	●	●	●
63	▲●#	▲●#	▲●#	▲●#	▲●#	●#	●#	●#	●#	●#	●	●	●	●
80	▲●#	▲●#	▲●#	▲●#	▲●#	●#	●#	●#	●#	●#	●	●	●	●
100	▲●#	▲●#	▲●#	▲●#	▲●#	●#	●#	●#	●#	●#	●	●	●	●

- ▲ **WB - WBM SEMPLICE EFFETTO MAGNETICO - SINGLE-ACTING MAGNETIC**
- ▲ **WD - WDM SEMPLICE EFFETTO MAGNETICO - MOLLA IN SPINTA - SINGLE-ACTING MAGNETIC - SPRING THRUST**
- **WF - WFM DOPPIO EFFETTO MAGNETICO - DOUBLE ACTING MAGNETIC**
- **WJ - WJM DOPPIO EFFETTO STELO PASSANTE MAGNETICO - DOUBLE ACTING MAGNETIC WITH DOUBLE ROD END**
- # **WFA DOPPIO EFFETTO MAGNETICO ANTIROTAZIONE - DOUBLE-ACTING MAGNETIC ANTIROTATION**

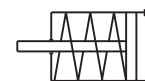

Ø20-25

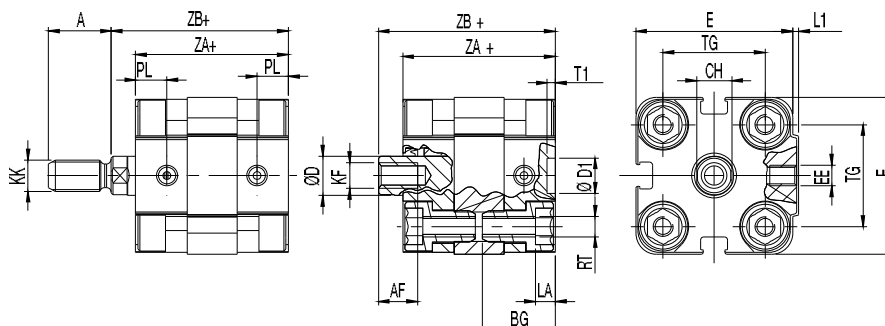

Ø32-40-50-63-80-100

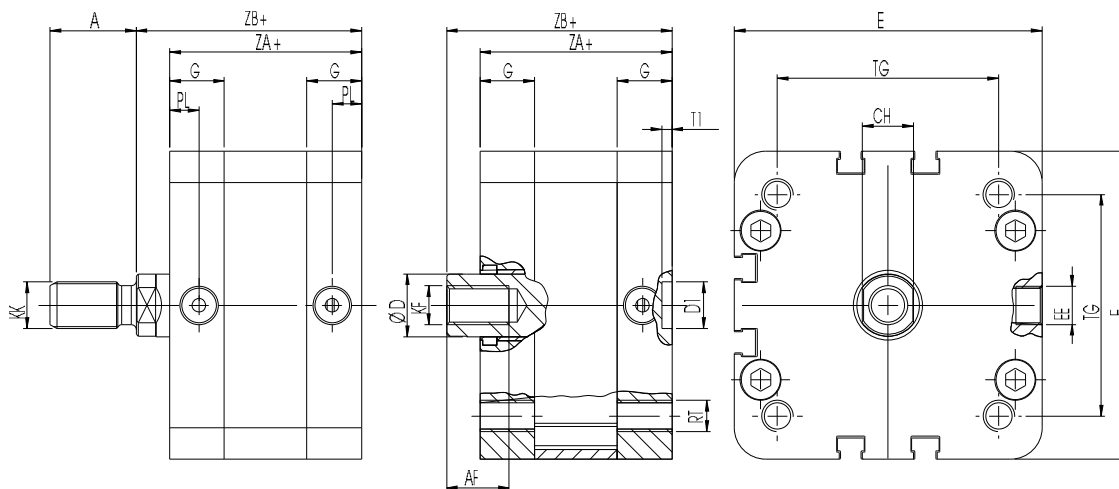

+ = aggiungere la corsa + = add stroke
 ++ = aggiungere 2 volte la corsa ++ = double stroke dimension and add it

*Come UNITOP - *Like UNITOP

WB - WBM

SEMPLICE EFFETTO MAGNETICO - SINGLE-ACTING MAGNETIC

ø mm	øD	E	L1	A	KK	CH	AF	KF	BG	LA	RT	G	TG	EE	PL	øD1	T1	ZA+	ZB +
*20	10	36	1,5	16	M8x1,25	9	10	M6	18,5	5	M5	-	22	M5	8	*6	*4	*39	*45
*25	10	40	1,5	16	M8x1,25	9	10	M6	18,5	5	M5	-	26	M5	8	*6	*4	39	45,5
32	12	49	-	19	M10x1,25	10	12	M8	-	-	M6	14,5	32,5	G1/8	7,5	9	2,1	44	51
40	12	55	-	19	M10x1,25	10	12	M8	-	-	M6	15	38	G1/8	7,5	9	2,1	45	52
50	16	68	-	22	M12x1,25	13	16	M10	-	-	M8	14,5	46,5	G1/8	7,5	12	2,6	45	53
63	16	78,5	-	22	M12x1,25	13	16	M10	-	-	M8	14	56,5	G1/8	7,5	12	2,6	49	57,5
80	20	98	-	28	M16x1,5	17	20	M12	-	-	M10	15,5	72	G1/8	7,5	12	2,6	54	64
100	25	120	-	28	M16x1,5	22	20	M12	-	-	M10	20	89	G1/8	7,5	12	2,6	67	77

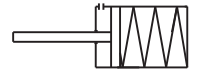
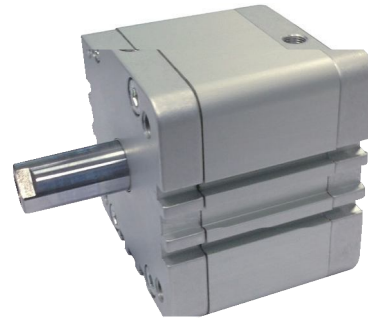
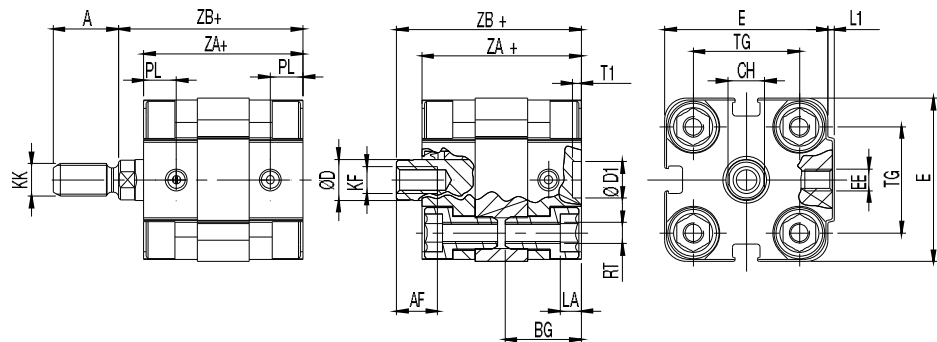
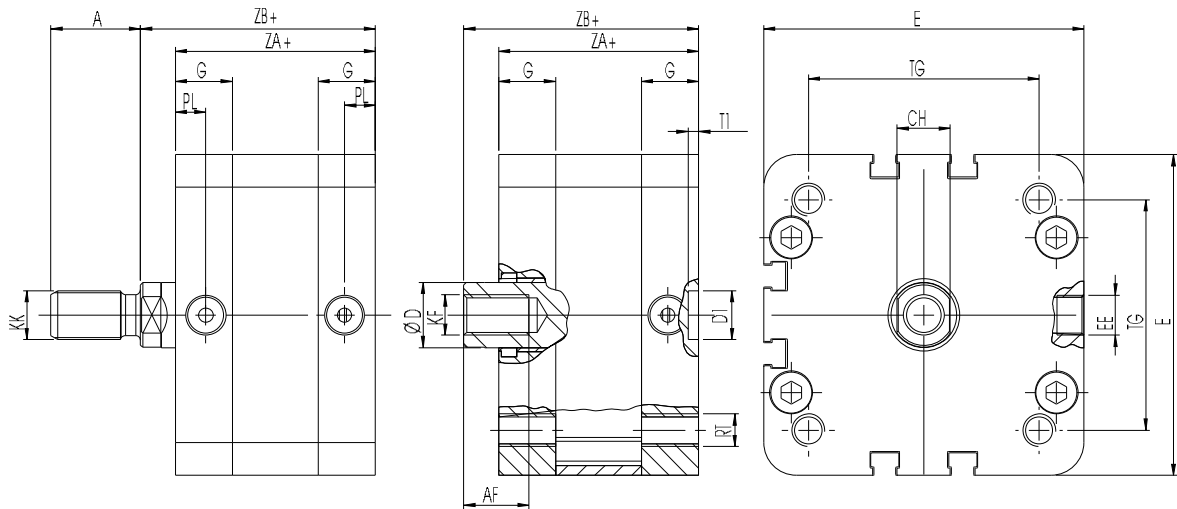
Ø20-25

Ø32-40-50-63-80-100

+= aggiungere la corsa

+= add stroke

+= aggiungere 2 volte la corsa

+= double stroke dimension and add it

*Come UNITOP - *Like UNITOP

WD - WDM

SEMPLICE EFFETTO MAGNETICO - MOLLA IN SPINTA - SINGLE ACTING MAGNETIC - SPRING THRUST

ø mm	øD	E	L1	A	KK	CH	AF	KF	BG	LA	RT	G	TG	EE	PL	øD1	T1	ZA+	ZB ++
*20	10	36	1,5	16	M8x1,25	9	10	M6	18,5	5	M5	-	22	M5	8	*6	*4	*39	*45
*25	10	40	1,5	16	M8x1,25	9	10	M6	18,5	5	M5	-	26	M5	8	*6	*4	39	45,5
32	12	49	-	19	M10x1,25	10	12	M8	-	-	M6	14,5	32,5	G1/8	7,5	9	2,1	44	51
40	12	55	-	19	M10x1,25	10	12	M8	-	-	M6	15	38	G1/8	7,5	9	2,1	45	52
50	16	68	-	22	M12x1,25	13	16	M10	-	-	M8	14,5	46,5	G1/8	7,5	12	2,6	45	53
63	16	78,5	-	22	M12x1,25	13	16	M10	-	-	M8	14	56,5	G1/8	7,5	12	2,6	49	57,5
80	20	98	-	28	M16x1,5	17	20	M12	-	-	M10	15,5	72	G1/8	7,5	12	2,6	54	64
100	25	120	-	28	M16x1,5	22	20	M12	-	-	M10	20	89	G1/8	7,5	12	2,6	67	77

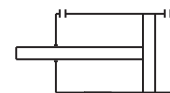
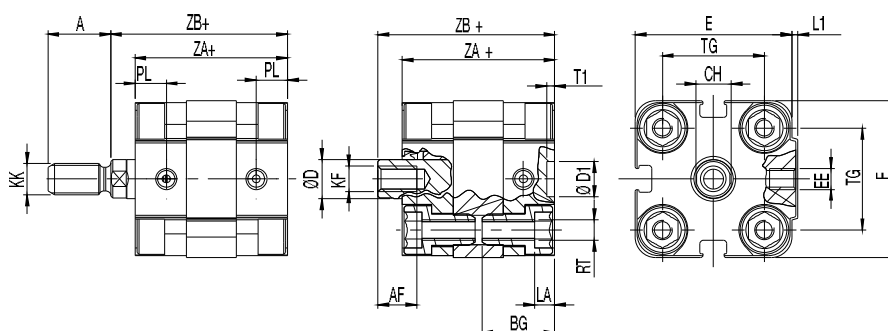
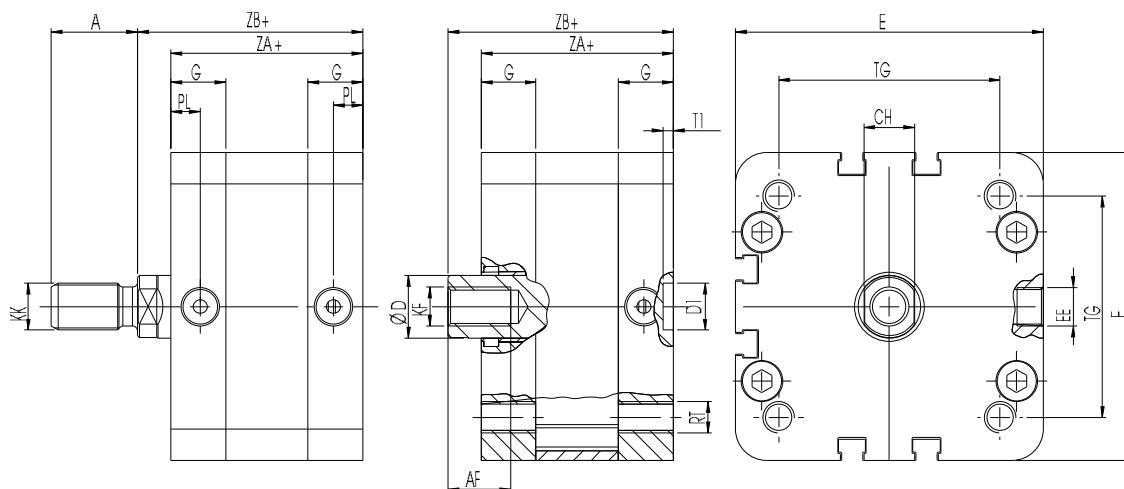
Ø20-25

Ø32-40-50-63-80-100

+= aggiungere la corsa += add stroke
 ++= aggiungere 2 volte la corsa ++= double stroke dimension and add it

*Come UNITOP - *Like UNITOP

WF - WFM

DOPPIO EFFETTO MAGNETICO - DOUBLE-ACTING MAGNETIC

ø mm	øD	E	L1	A	KK	CH	AF	KF	BG	LA	RT	G	TG	EE	PL	øD1	T1	ZA+	ZB +
*20	10	36	1,5	16	M8x1,25	9	10	M6	18,5	5	M5	-	22	M5	8	*6	*4	*39	*45
*25	10	40	1,5	16	M8x1,25	9	10	M6	18,5	5	M5	-	26	M5	8	*6	*4	39	45,5
32	12	49	-	19	M10x1,25	10	12	M8	-	-	M6	14,5	32,5	G1/8	7,5	9	2,1	44	51
40	12	55	-	19	M10x1,25	10	12	M8	-	-	M6	15	38	G1/8	7,5	9	2,1	45	52
50	16	68	-	22	M12x1,25	13	16	M10	-	-	M8	14,5	46,5	G1/8	7,5	12	2,6	45	53
63	16	78,5	-	22	M12x1,25	13	16	M10	-	-	M8	14	56,5	G1/8	7,5	12	2,6	49	57,5
80	20	98	-	28	M16x1,5	17	20	M12	-	-	M10	15,5	72	G1/8	7,5	12	2,6	54	64
100	25	120	-	28	M16x1,5	22	20	M12	-	-	M10	20	89	G1/8	7,5	12	2,6	67	77

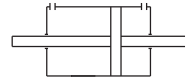
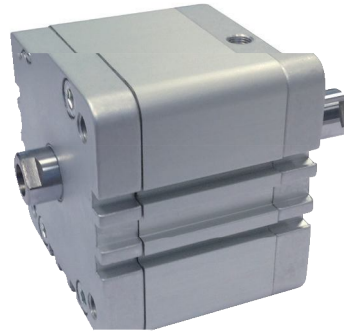
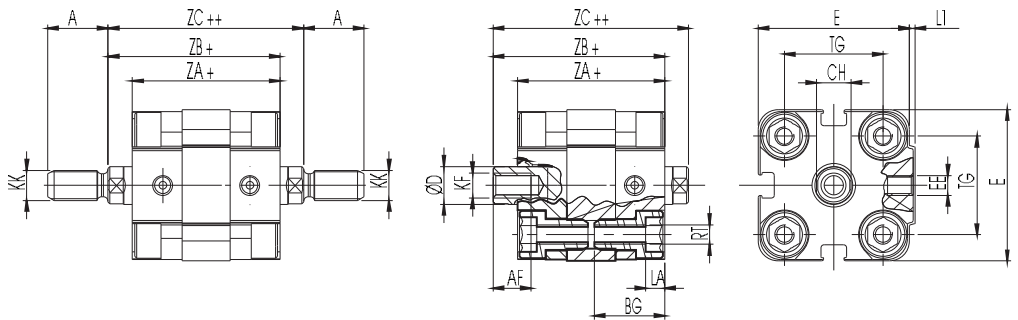
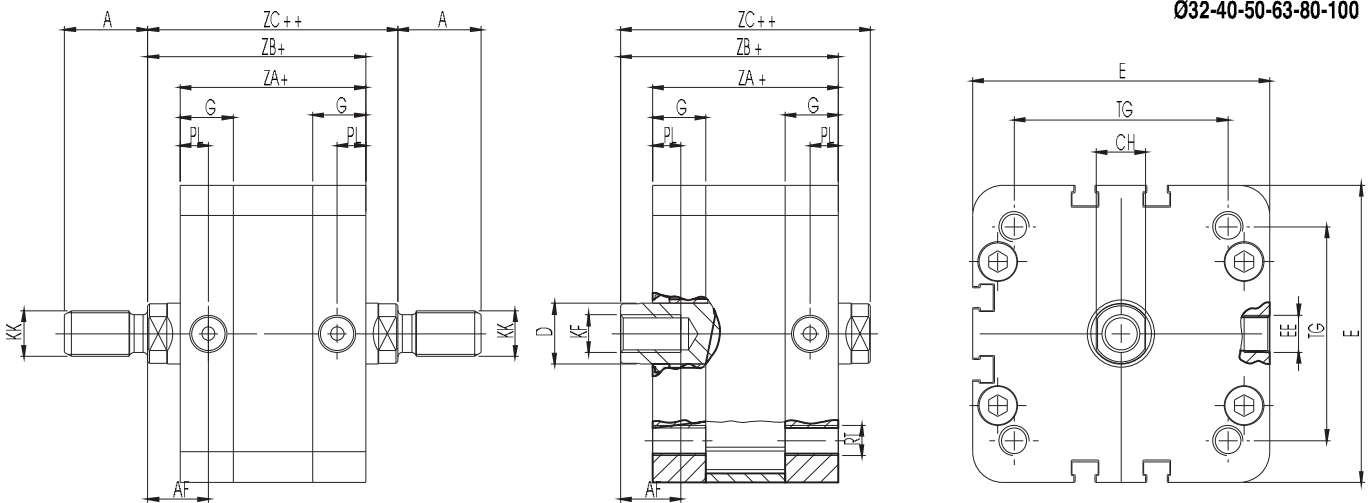
Ø20-25

Ø32-40-50-63-80-100

+= aggiungere la corsa

+= add stroke

++= aggiungere 2 volte la corsa

++= double stroke dimension and add it

*Come UNITOP - *Like UNITOP

WJ - WJM

DOPPIO EFFETTO STELO PASSANTE MAGNETICO - DOUBLE ACTING MAGNETIC WITH DOUBLE ROD END

ø mm	øD	E	L1	A	KK	CH	AF	KF	BG	LA	RT	G	TG	EE	PL	ZA+	ZB+	ZC++
*20	10	36	1,5	16	M8x1,25	9	10	M6	18,5	5	M5	-	22	M5	8	*39	*45	*51
25	10	40	1,5	16	M8x1,25	9	10	M6	18,5	5	M5	-	26	M5	8	39	45,5	51,5
32	12	49	-	19	M10x1,25	10	12	M8	-	-	M6	14,5	32,5	G1/8	7,5	44	51	58
40	12	55	-	19	M10x1,25	10	12	M8	-	-	M6	15	38	G1/8	7,5	45	52	59
50	16	68	-	22	M12x1,25	13	16	M10	-	-	M8	14,5	46,5	G1/8	7,5	45	53	61
63	16	78,5	-	22	M12x1,25	13	16	M10	-	-	M8	14	56,5	G1/8	7,5	49	57,5	66
80	20	98	-	28	M16x1,5	17	20	M12	-	-	M10	15,5	72	G1/8	7,5	54	64	74
100	25	120	-	28	M16x1,5	22	20	M12	-	-	M10	20	89	G1/8	7,5	67	77	87

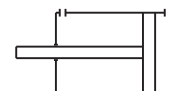
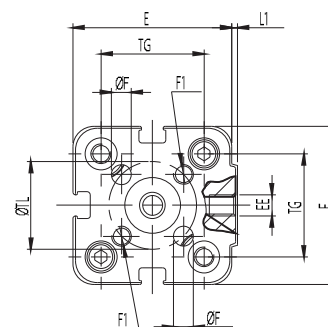
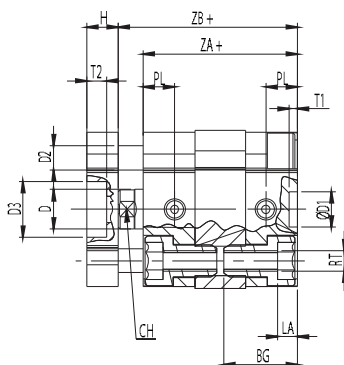
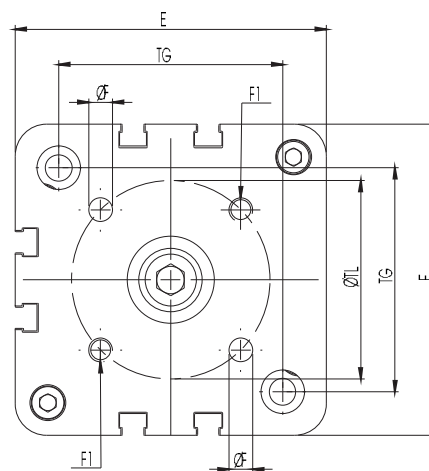
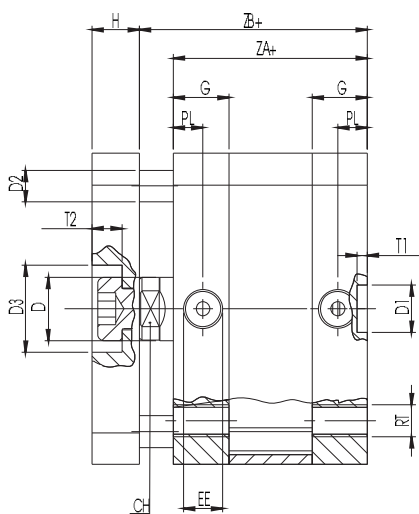
Ø20-25

Ø32-40-50-63-80-100

+= aggiungere la corsa

+= add stroke

++= aggiungere 2 volte la corsa

++= double stroke dimension and add it

*Come UNITOP - *Like UNITOP

WFA

DOPPIO EFFETTO MAGNETICO ANTIROTAZIONE - DOUBLE-ACTING MAGNETIC ANTIROTATION

ø mm	øD	E	L1	CH	AF	KF	BG	LA	RT	G	TG	EE	PL	øD1	T1	ØTL	H	øF	F1	D2	D3	T2	ZA+	ZB+
*20	10	36	1,5	9	10	M6	18,5	5	M5	-	22	M5	8	*6	*4	17	8	4	M4	6	10,5	5	*39	*45
*25	10	40	1,5	9	10	M6	18,5	5	M5	-	26	M5	8	*6	*4	22	8	5	M5	6	14	5	39	45,5
32	12	49	-	10	12	M8	-	-	M6	14,5	32,5	G1/8	7,5	9	2,1	28	10	5	M5	6	17	6	44	51
40	12	55	-	10	12	M8	-	-	M6	15	38	G1/8	7,5	9	2,1	33	10	5	M5	6	17	6	45	52
50	16	68	-	13	16	M10	-	-	M8	14,5	46,5	G1/8	7,5	12	2,6	42	12	6	M6	8	22	7,5	45	53
63	16	78,5	-	13	16	M10	-	-	M8	14	56,5	G1/8	7,5	12	2,6	50	12	6	M6	8	22	7,5	49	57,5
80	20	98	-	17	20	M12	-	-	M10	15,5	72	G1/8	7,5	12	2,6	65	14	8	M8	12	24	10,5	54	64
100	25	120	-	22	20	M12	-	-	M10	20	89	G1/8	7,5	12	2,6	80	14	10	M10	12	24	10,5	67	77