

Cilindri Corsa Breve / Short Stroke Cylinders

Le dimensioni d'ingombro dei cilindri a corsa breve sono per eccellenza le più contenute, questa caratteristica li rende particolarmente adatti per l'impiego in spazi ridotti. Il profilo adottato è quello dell'ultima generazione, grazie alle apposite guide ricavate sui tre lati permette l'utilizzo dei sensori a scomparsa. Gli interassi di fissaggio per gli alesaggi 20 e 25 mm sono a norma UNITOP mentre dal 32 al 100 mm sono quelli dei cilindri classe VDMA ISO 6431.

The overall dimensions of the short stroke cylinders are absolutely the smallest, this characteristic identify this line as the most suitable to be used in reduced spaces. Over the last generation outside profile, on three sides, it has been obtained the guides on whom it is possible to assembly the disappearance switches and elastic bumpers at the stroke end. The fixing distance between cylinder's centers for diameter 20 and 25 mm are in conformity with the standard UNITOP, from 32 to 100 mm match the VDMA ISO 6431 standards.



Caratteristiche Tecniche / Technical Characteristics

Pressioni / Pressures

Pressione minima / Minimum pressure: **1 bar** (0.1 MPa)
 Pressione massima / Maximum pressure: **10 bar** (1 MPa)

Temperature / Temperatures

Temperatura minima / Minimum temperature: 0 °C
 (-20 °C con aria secca / with dry air)
 Temperatura massima / Maximum temperature: +80 °C

Fluidi compatibili / Fluids

Aria compressa filtrata e lubrificata e non lubrificata.
 Filtered and lubricated compressed air as well as non lubricated air.

Funzionamento / Functioning

Semplice effetto magnetico, Doppio effetto magnetico
 Stelo singolo e passante magnetico, Antirrotazione magnetico.
 Single and Double-acting magnetic. Single or through piston rod magnetic Antirotation magnetic.

Alesaggi / Bores

Da 12 a 100 mm / From 12 to 100 mm

Corse / Strokes

Corse Standard / Standard Strokes
 Da 5 a 100 mm / From 5 to 100 mm

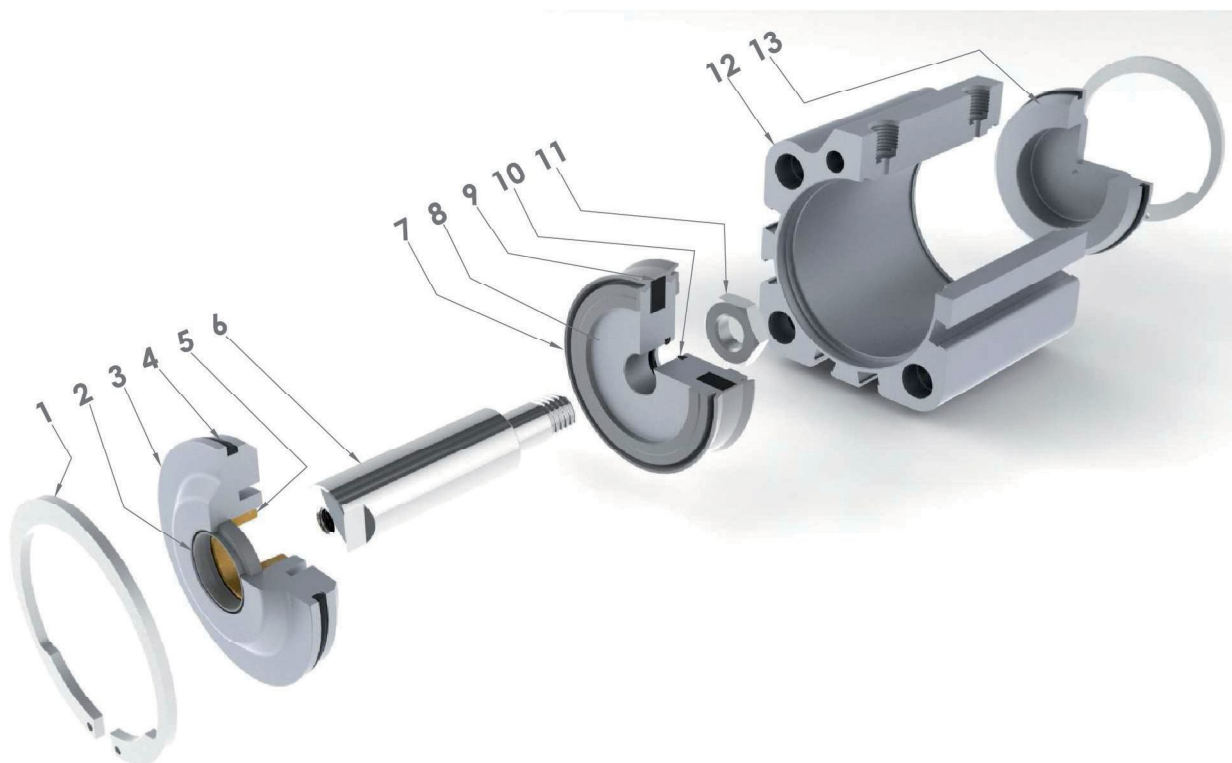
Caratteristiche Tecniche / Technical Characteristics

Materiali e Componenti / Component Parts and Materials

1 Seeger in acciaio	1 Steel Seeger
2 Guarnizione asta in poliuretano	2 Polyurethane Rod Seal
3 Testata anteriore in alluminio anodizzato	3 Anodised aluminium Front cover
4 Guarnizioni in NBR	4 NBR Seals
5 Bronzina in bronzo sinterizzato	5 Sintered bronze Bearing
6 Asta pistone acciaio cromato (AISI 303 da 12 a 25) (C40 da 32 a 100)	6 Chrome steel Piston rod (AISI 303 from 12 to 25)(C40 from 32 to 100)
7 Guarnizione pistone in poliuretano	7 Polyurethane Piston Seal
8 Pistone in alluminio	8 Aluminium Piston
9 Magnete in plastoferrite	9 Plastoferrite Magnet
10 O-Ring in NBR	10 O-Ring in NBR
11 Dado pistone in acciaio zincato	11 Zinc-plated steel Piston Nut
12 Camicia cilindro in alluminio anodizzato	12 Anodised aluminium Cylinder shape body
13 Testata posteriore in alluminio anodizzato	13 Anodised aluminium Back cover

NB: LE TESTATE ANTERIORI E POSTERIORI Ø12 Ø16 Ø20 Ø25 SONO IN OTTONE GIALLO
NB: FRONT AND BACK COVER Ø12 Ø16 Ø20 Ø25 ARE MADE IN BRASS

Forze e Consumi / Forces And Consumptions

FORZE DI SPINTA E TIRO - THRUST AND TRACTION FORCES

Ø Cilindro Ø Cylinder	Ø Stelo Ø Rod	Superficie utile in mm ² Working Surface in mm ²	Pressione di lavoro in bar Operating pressure in bar									
			1	2	3	4	5	6	7	8	9	10
			Forza sviluppata in N Output force in N									
Ø12	6	Spinta / Thrust = 113	10	20	30	40	50	60	70	80	90	100
		Trazione / Traction = 85	7,5	15	22	30	37	45	52	60	68	75
Ø16	8	Spinta / Thrust = 200	18	35	53	70	90	105	125	145	160	180
		Trazione / Traction = 150	13	26	40	53	65	80	95	105	120	130
Ø20	10	Spinta / Thrust = 314	28	55	85	110	140	170	195	220	250	280
		Trazione / Traction = 235	21	42	60	85	105	125	150	170	190	210
Ø25	10	Spinta / Thrust = 490	44	88	132	176	220	264	308	352	396	440
		Trazione / Traction = 412	36	72	108	144	180	216	252	288	324	360
Ø32	12	Spinta / Thrust = 804	72	144	216	288	360	432	504	576	648	720
		Trazione / Traction = 691	62	124	186	248	310	372	434	496	558	620
Ø40	12	Spinta / Thrust = 1257	110	220	330	440	550	660	770	880	990	1100
		Trazione / Traction = 1144	100	200	300	400	500	600	700	800	900	1000
Ø50	16	Spinta / Thrust = 1963	175	350	525	700	875	1050	1225	1400	1575	1750
		Trazione / Traction = 1762	155	310	465	620	775	930	1085	1240	1395	1550
Ø63	16	Spinta / Thrust = 3117	280	560	840	1120	1400	1680	1960	2240	2520	2800
		Trazione / Traction = 2916	260	520	780	1040	1300	1560	1820	2080	2340	2600
Ø80	20	Spinta / Thrust = 5027	450	900	1350	1800	2250	2700	3150	3600	4050	4500
		Trazione / Traction = 4712	420	840	1260	1680	2100	2520	2940	3360	3780	4200
Ø100	25	Spinta / Thrust = 7854	700	1400	2100	2800	3500	4200	4900	5650	6360	7000
		Trazione / Traction = 7363	660	1320	1980	2640	3300	3960	4620	5280	5940	6600

FORZE DELLA MOLLA - SPRING TRACTION FORCES

Ø Cilindri Ø Cylinder	Carico Molla Load Spring	Corsa / Stroke							
		5	10	15	20	25	30	40	50
		Forza sviluppata in N Output force in N							
Ø12	Carico Molla a Riposo / Load of spring at rest	7,5	6,8	6	5,2	4,5			
	Carico Molla Compressa / Load of compressed spring	8	8	8	8	8			
Ø16	Carico Molla a Riposo / Load of spring at rest	12,3	10,8	9,5	7,8	6,5			
	Carico Molla Compressa / Load of compressed spring	13,3	13,3	13,3	13,3	13,3			
Ø20	Carico Molla a Riposo / Load of spring at rest	15,7	14	12,2	10,4	8,7			
	Carico Molla Compressa / Load of compressed spring	17,4	17,4	17,4	17,4	17,4			
Ø25	Carico Molla a Riposo / Load of spring at rest	19,5	18,5	17,3	16	15			
	Carico Molla Compressa / Load of compressed spring	22	22	22	22	22			
Ø32	Carico Molla a Riposo / Load of spring at rest	27,8	25,3	22,8	20,2	17,7			
	Carico Molla Compressa / Load of compressed spring	30	30	30	30	30			
Ø40	Carico Molla a Riposo / Load of spring at rest	36,4	34	31,7	29,5	27			
	Carico Molla Compressa / Load of compressed spring	36	36	36	36	36			
Ø50	Carico Molla a Riposo / Load of spring at rest	32	30,5	29	27,8	26,5			
	Carico Molla Compressa / Load of compressed spring	35	35	35	35	35			
Ø63	Carico Molla a Riposo / Load of spring at rest	61	58,5	56,3	53,5	51,5			
	Carico Molla Compressa / Load of compressed spring	64,8	64,8	64,8	64,8	64,8			
Ø80	Carico Molla a Riposo / Load of spring at rest	91,3	88	85	82	78,7			
	Carico Molla Compressa / Load of compressed spring	94	94	94	94	94			
Ø100	Carico Molla a Riposo / Load of spring at rest	150	145	140	134	129			
	Carico Molla Compressa / Load of compressed spring	156	156	156	156	156			

CONSUMI CILINDRO - CYLINDER AIR CONSUMPTION

Ø Cilindro Ø Cylinder	Ø Stelo Ø Rod	Superficie utile in mm ² Working Surface in mm ²	Pressione di lavoro in bar Operating pressure in bar									
			1	2	3	4	5	6	7	8	9	10
			Consumo aria in NL per ogni 10mm. di corsa Air consumption in NL for each 10mm. of stroke									
Ø12	6	Spinta / Thrust = 113	0,002	0,003	0,005	0,006	0,007	0,008	0,009	0,010	0,011	0,012
		Trazione / Traction = 85	0,002	0,003	0,003	0,004	0,005	0,006	0,007	0,008	0,009	0,009
Ø16	8	Spinta / Thrust = 200	0,004	0,006	0,008	0,010	0,012	0,014	0,016	0,018	0,020	0,022
		Trazione / Traction = 150	0,003	0,005	0,006	0,008	0,009	0,011	0,012	0,014	0,015	0,017
Ø20	10	Spinta / Thrust = 314	0,006	0,009	0,013	0,016	0,019	0,022	0,025	0,028	0,031	0,035
		Trazione / Traction = 235	0,005	0,007	0,009	0,012	0,014	0,016	0,019	0,021	0,024	0,026
Ø25	10	Spinta / Thrust = 490	0,010	0,015	0,020	0,025	0,029	0,034	0,039	0,044	0,049	0,054
		Trazione / Traction = 412	0,008	0,012	0,016	0,021	0,025	0,029	0,033	0,037	0,041	0,045
Ø32	12	Spinta / Thrust = 804	0,016	0,024	0,032	0,040	0,048	0,056	0,064	0,072	0,080	0,088
		Trazione / Traction = 691	0,014	0,021	0,028	0,035	0,041	0,048	0,055	0,062	0,069	0,076
Ø40	12	Spinta / Thrust = 1257	0,025	0,038	0,050	0,063	0,075	0,088	0,101	0,113	0,126	0,138
		Trazione / Traction = 1144	0,023	0,034	0,046	0,057	0,069	0,080	0,092	0,103	0,114	0,126
Ø50	16	Spinta / Thrust = 1963	0,039	0,059	0,079	0,098	0,118	0,137	0,157	0,177	0,196	0,216
		Trazione / Traction = 1762	0,035	0,053	0,070	0,088	0,106	0,123	0,141	0,159	0,176	0,194
Ø63	16	Spinta / Thrust = 3117	0,062	0,094	0,125	0,156	0,187	0,218	0,249	0,281	0,312	0,343
		Trazione / Traction = 2916	0,058	0,087	0,117	0,146	0,175	0,204	0,233	0,262	0,292	0,321
Ø80	20	Spinta / Thrust = 5027	0,101	0,151	0,201	0,251	0,302	0,352	0,402	0,452	0,503	0,553
		Trazione / Traction = 4712	0,094	0,141	0,188	0,236	0,283	0,330	0,377	0,424	0,471	0,518
Ø100	25	Spinta / Thrust = 7854	0,157	0,236	0,314	0,393	0,471	0,550	0,628	0,707	0,785	0,864
		Trazione / Traction = 7363	0,147	0,221	0,295	0,368	0,442	0,515	0,589	0,663	0,736	0,810

Tabella dei codici di ordinazione - Ordering codes

B	B	0 3 2	0 0 2 5
<p>Corsa mm. / Stroke mm. 5 - 10 - 15 - 20 - 25 - 30 - 40 - 50 - 75 - 100 A richiesta corse intermedie o superiori <i>Intermediate or higher strokes are available upon request.</i></p>			
<p>Diametro mm. / Diameter mm. 12-16-20-25-32-40-50-63-80-100</p>			
<p>Esecuzione / Execution</p> <p>B = Semplice Effetto Magnetico - Single-Acting Magnetic D = Semplice Effetto Magnetico - Molla In Spinta - Single-Acting Magnetic - Spring Thrust F = Doppio Effetto Magnetico - Double Acting Magnetic J = Doppio Effetto Stelo Passante Magnetico - Double Acting Magnetic With Double Rod End FA = Doppio Effetto Magnetico Antirotazione - Double Acting Magnetic Antirotation</p>			
<p>B= Serie Corsa Breve / Short Stroke</p>			

CORSE STANDARD mm. - STD STROKES

Ø mm.	5	10	15	20	25	30	40	50	75	100
12	▲●	▲●	▲●	▲●	▲●	●	●			
16	▲●	▲●	▲●	▲●	▲●	●	●			
20	▲●	▲●	▲●	▲●	▲●	●	●	●		
25	▲●	▲●	▲●	▲●	▲●	●	●	●		
32	▲●	▲●	▲●	▲●	▲●	▲●	▲●	▲●	●	●
40	▲●	▲●	▲●	▲●	▲●	▲●	▲●	▲●	●	●
50	▲●	▲●	▲●	▲●	▲●	▲●	▲●	▲●	●	●
63	▲●	▲●	▲●	▲●	▲●	▲●	▲●	▲●	●	●
80	▲●	▲●	▲●	▲●	▲●	▲●	▲●	▲●	●	●
100	▲●	▲●	▲●	▲●	▲●	▲●	▲●	▲●	●	●

- ▲ **BB** **SEMPLICE EFFETTO MAGNETICO - SINGLE-ACTING MAGNETIC**
- ▲ **BD** **SEMPLICE EFFETTO MAGNETICO - MOLLA IN SPINTA - SINGLE-ACTING MAGNETIC - SPRING THRUST**
- **BF** **DOPPIO EFFETTO MAGNETICO - DOUBLE ACTING MAGNETIC**
- **BJ** **DOPPIO EFFETTO STELO PASSANTE MAGNETICO - DOUBLE ACTING MAGNETIC WITH DOUBLE ROD END**
- **BFA** **DOPPIO EFFETTO MAGNETICO ANTIROTAZIONE - DOUBLE-ACTING MAGNETIC ANTIROTATION**

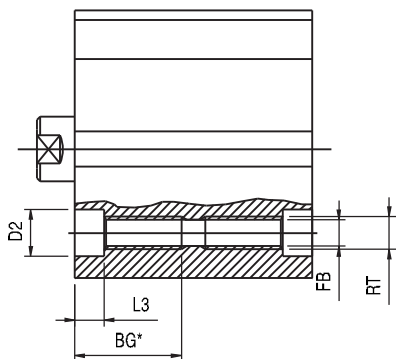

D12-16-20-25

D32-40-50-63-80-100

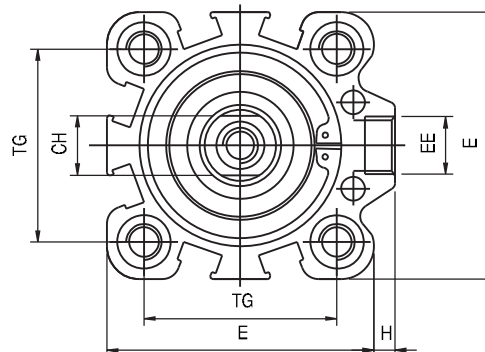
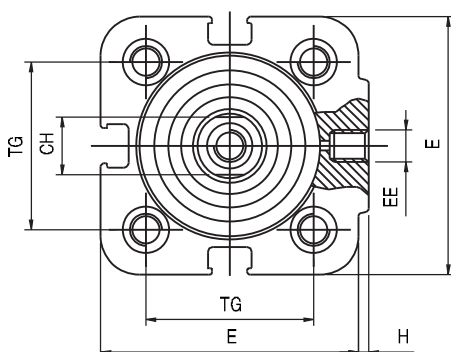
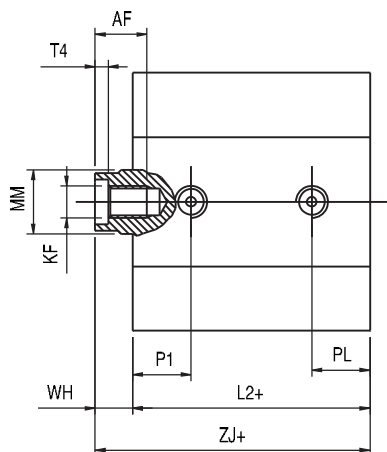

+= aggiungere la corsa += add stroke
 * = per corsa corta filetto passante * = Through threads only on small strokes

BB

SEMPLICE EFFETTO MAGNETICO - SINGLE-ACTING MAGNETIC

Ø mm.	AF	RT	BG*	D2Ø	E	EE	FBØ	H	KF	L2+	L3	MMØ	P1	PL	T4	TG	WH	ZJ+	CH
12	6	M4	12.5	5.5	29	M5	3.3	1	M3	28	3.5	6	7.5	7.5	1.5	18	6	34	5
16	8	M4	14.5	5.5	29	M5	3.3	1	M4	30.5	3.5	8	8.5	8.5	2	18	6	36.5	7
20	8	M5	16.5	7.2	36	M5	4.2	1.5	M5	31.5	4.5	10	9	9	2	22	6	37.5	9
25	8	M5	16.5	7.2	40	M5	4.2	1.5	M5	31.5	4.5	10	9	9	2	26	6	37.5	9
32	10	M6	21.7	8.5	45	G1/8	5	3.5	M6	32	5.7	12	10	10	2.8	32.5	7	39	10
40	10	M6	21.7	8.5	52	G1/8	5	5	M6	38.5	5.7	12	11	11	2.8	38	7.2	45.7	10
50	12	M8	22.8	10	63.5	G1/8	6.8	7	M8	39	6.8	16	11	11	3.5	46.5	8.5	47.5	13
63	12	M8	22.8	10	77	G1/8	6.8	7	M8	46	6.8	16	11.5	11.5	3.5	56.5	8	54	13
80	16	M10	25	13	92	G1/8	8.5	10	M10	54	9	20	14	14	4.5	72	11	65	17
100	20	M10	25	13	113	G1/4	8.5	13	M12	65	9	25	17.5	17.5	6	89	12	77	22

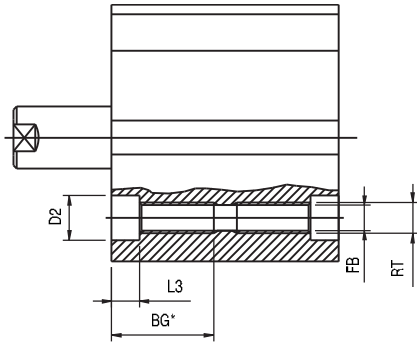

D12-16-20-25

D32-40-50-63-80-100

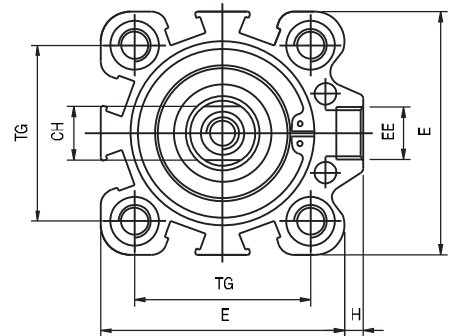
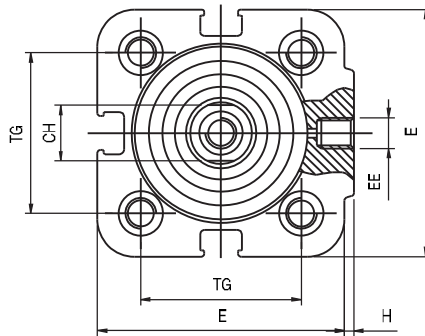
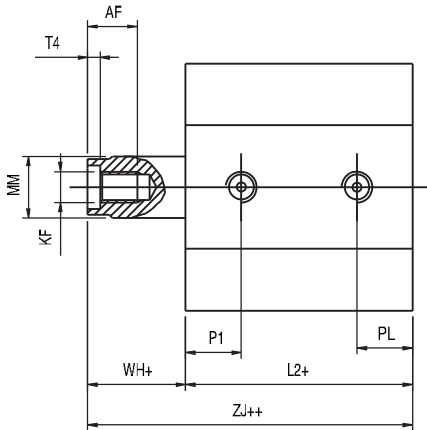

+= aggiungere la corsa += add stroke
 += aggiungere 2 volte la corsa += double stroke dimension and add it
 * = per corsa corta filetto passante * = Through threads only on small strokes

BD

SEMPLICE EFFETTO MAGNETICO - MOLLA IN SPINTA - SINGLE ACTING MAGNETIC - SPRING THRUST

Ø mm.	AF	RT	BG*	D2Ø	E	EE	FBØ	H	KF	L2+	L3	MMØ	P1	PL	T4	TG	WH+	ZJ++	CH
12	6	M4	12.5	5.5	29	M5	3.3	1	M3	28	3.5	6	7.5	7.5	1.5	18	6	34	5
16	8	M4	14.5	5.5	29	M5	3.3	1	M4	30.5	3.5	8	8.5	8.5	2	18	6	36.5	7
20	8	M5	16.5	7.2	36	M5	4.2	1.5	M5	31.5	4.5	10	9	9	2	22	6	37.5	9
25	8	M5	16.5	7.2	40	M5	4.2	1.5	M5	31.5	4.5	10	9	9	2	26	6	37.5	9
32	10	M6	21.7	8.5	45	G1/8	5	3.5	M6	32	5.7	12	10	10	2.8	32.5	7	39	10
40	10	M6	21.7	8.5	52	G1/8	5	5	M6	38.5	5.7	12	11	11	2.8	38	7.2	45.7	10
50	12	M8	22.8	10	63.5	G1/8	6.8	7	M8	39	6.8	16	11	11	3.5	46.5	8.5	47.5	13
63	12	M8	22.8	10	77	G1/8	6.8	7	M8	46	6.8	16	11.5	11.5	3.5	56.5	8	54	13
80	16	M10	25	13	92	G1/8	8.5	10	M10	54	9	20	14	14	4.5	72	11	65	17
100	20	M10	25	13	113	G1/4	8.5	13	M12	65	9	25	17.5	17.5	6	89	12	77	22

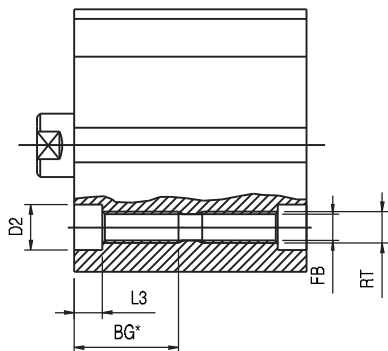

D12-16-20-25

D32-40-50-63-80-100

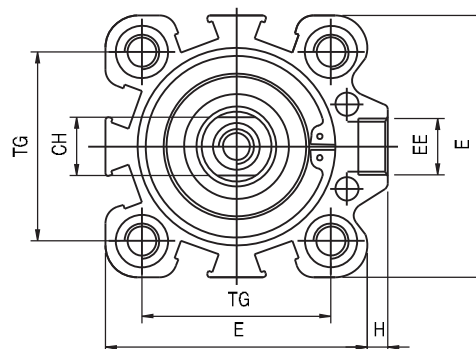
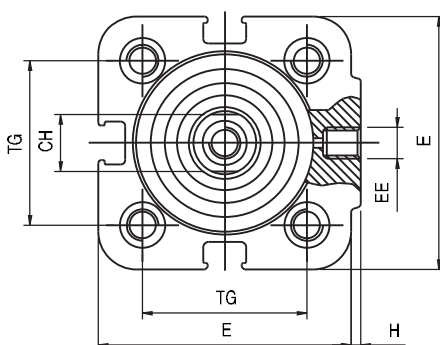
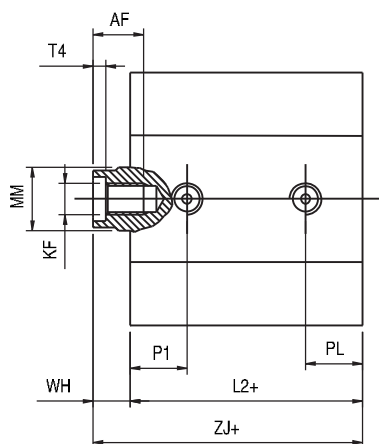

+ = aggiungere la corsa + = add stroke
 * = per corsa corta filetto passante * = Through threads only on small strokes

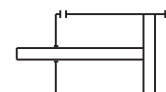

BF

DOPPIO EFFETTO MAGNETICO - DOUBLE-ACTING MAGNETIC

Ø mm.	AF	RT	BG*	D2Ø	E	EE	FBØ	H	KF	L2+	L3	MMØ	P1	PL	T4	TG	WH	ZJ+	CH
12	6	M4	12.5	5.5	29	M5	3.3	1	M3	28	3.5	6	7.5	7.5	1.5	18	6	34	5
16	8	M4	14.5	5.5	29	M5	3.3	1	M4	30.5	3.5	8	8.5	8.5	2	18	6	36.5	7
20	8	M5	16.5	7.2	36	M5	4.2	1.5	M5	31.5	4.5	10	9	9	2	22	6	37.5	9
25	8	M5	16.5	7.2	40	M5	4.2	1.5	M5	31.5	4.5	10	9	9	2	26	6	37.5	9
32	10	M6	21.7	8.5	45	G1/8	5	3.5	M6	32	5.7	12	10	10	2.8	32.5	7	39	10
40	10	M6	21.7	8.5	52	G1/8	5	5	M6	38.5	5.7	12	11	11	2.8	38	7.2	45.7	10
50	12	M8	22.8	10	63.5	G1/8	6.8	7	M8	39	6.8	16	11	11	3.5	46.5	8.5	47.5	13
63	12	M8	22.8	10	77	G1/8	6.8	7	M8	46	6.8	16	11.5	11.5	3.5	56.5	8	54	13
80	16	M10	25	13	92	G1/8	8.5	10	M10	54	9	20	14	14	4.5	72	11	65	17
100	20	M10	25	13	113	G1/4	8.5	13	M12	65	9	25	17.5	17.5	6	89	12	77	22

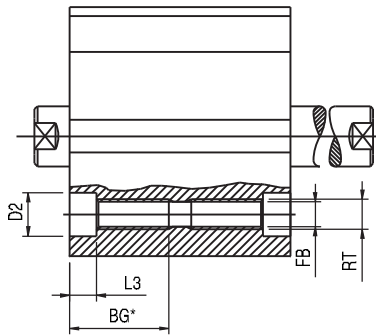

D12-16-20-25



D32-40-50-63-80-100

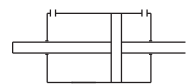
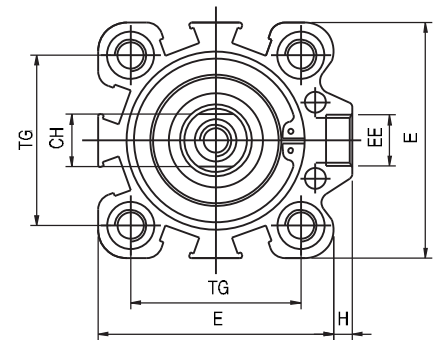
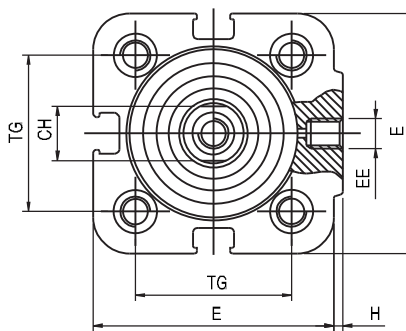
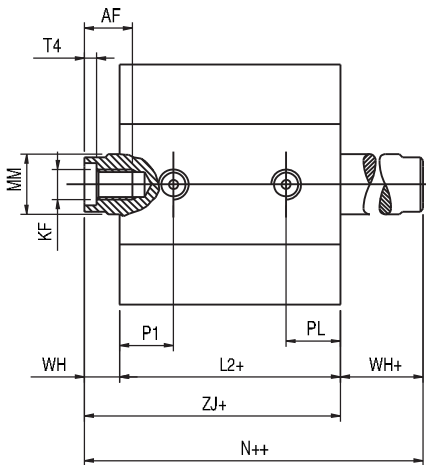

+= aggiungere la corsa += add stroke
 ++=aggiungere 2 volte la corsa ++ = double stroke dimension and add it
 * = per corsa corta filetto passante * = Through threads only on small strokes

BJ

DOPPIO EFFETTO STELO PASSANTE MAGNETICO - DOUBLE ACTING MAGNETIC WITH DOUBLE ROD END

Ø mm.	AF	RT	BG*	D2Ø	E	EE	FBØ	H	KF	CH	L2	L3	MMØ	P1	PL	T4	TG	N++	WH/WH+	ZJ+
12	6	M4	12.5	5.5	29	M5	3.3	1	M3	5	28	3.5	6	7.5	7.5	1.5	18	40	6	34
16	8	M4	14.5	5.5	29	M5	3.3	1	M4	7	30.5	3.5	8	8.5	8.5	2	18	42.5	6	36.5
20	8	M5	16.5	7.2	36	M5	4.2	1.5	M5	9	31.5	4.5	10	9	9	2	22	43.5	6	37.5
25	8	M5	16.5	7.2	40	M5	4.2	1.5	M5	9	31.5	4.5	10	9	9	2	26	43.5	6	37.5
32	10	M6	21.7	8.5	45	G1/8	5	3.5	M6	10	32	5.7	12	10	10	2.8	32.5	46	7	39
40	10	M6	21.7	8.5	52	G1/8	5	5	M6	10	38.5	5.7	12	11	11	2.8	38	53	7.2	45.7
50	12	M8	22.8	10	63.5	G1/8	6.8	7	M8	13	39	6.8	16	11	11	3.5	46.5	56	8.5	47.5
63	12	M8	22.8	10	77	G1/8	6.8	7	M8	13	46	6.8	16	11.5	11.5	3.5	56.5	62	8	54
80	16	M10	25	13	92	G1/8	8.5	10	M10	17	54	9	20	14	14	4.5	72	76	11	65
100	20	M10	25	13	113	G1/4	8.5	13	M12	22	65	9	25	17.5	17.5	6	89	89	12	77

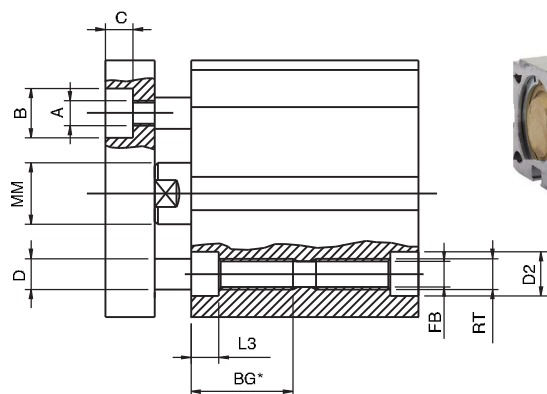

D12-16-20-25

D32-40-50-63-80-100

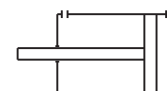
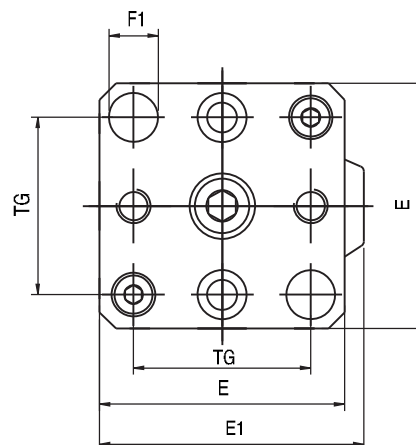
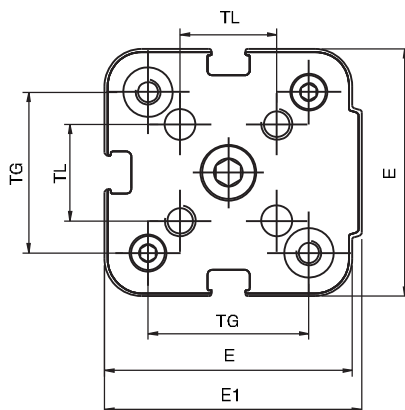
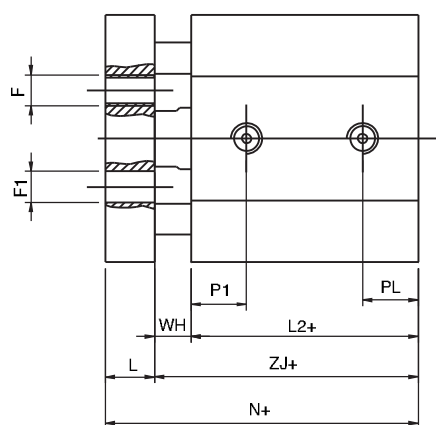

+= aggiungere la corsa += add stroke
 * = per corsa corta filetto passante * = Through threads only on small strokes

BFA

DOPPIO EFFETTO MAGNETICO ANTIROTAZIONE - DOUBLE-ACTING MAGNETIC ANTIROTATION

Ø mm.	A	BØ	C	DØ	E	E1	F	F1Ø	FBØ	RT	BG*	D2Ø	L	L2+	L3	MMØ	P1	PL	TG	TL	WH	ZJ+	N+
12	M3	6	3.5	4	28.2	30	M3	3	3.5	M4	12.5	5.5	5	28	3.5	6	7.5	7.5	18	9.9	6	34	39
16	M3	6	3.5	4	28.2	30	M3	3	3.5	M4	14.5	5.5	5	30.5	3.5	8	8.5	8.5	18	9.9	6	36.5	41.5
20	M3	6	3.5	6	35	37.5	M4	4	4.2	M5	16.5	7	8	31.5	4.5	10	9	9	22	12	6	37.5	45.5
25	M4	8	4.5	6	39	41.5	M5	5	4.2	M5	16.5	7	8	31.5	4.5	10	9	9	26	15.6	6	37.5	45.5
32	4.5	8	4.5	6	45	48.5	M5	9	5	M6	21.7	8.5	10	32	5.7	12	10	10	32.5	-	7	39	48
40	4.5	8	4.5	6	52	57	M5	9	5	M6	21.7	8.5	10	38.5	5.7	12	11	11	38	-	7.2	45.7	55.5
50	5.5	9	5.5	8	63.5	70.5	M6	10	6.8	M8	22.8	10	12	39	6.8	16	11	11	46.5	-	8.5	47.5	59
63	5.5	9	5.5	8	75	84	M6	14	6.8	M8	22.8	10	12	46	6.8	16	11.5	11.5	56.5	-	8	54	66
80	8.5	14	9	12	90	102	M8	14	8.5	M10	25	13	14	54	9	20	14	14	72	-	11	65	79
100	8.5	14	9	12	110	126	M8	17	8.5	M10	25	13	14	65	9	25	17.5	17.5	89	-	12	77	91

Componenti di fissaggio / Mounting Accessories

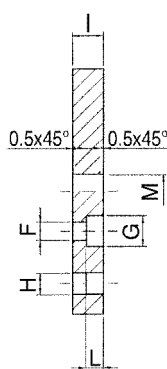
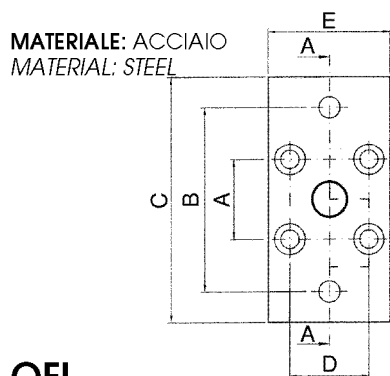

QFL

FLANGIA - FLANGE

Codice Code	Ø mm.	A	B	C	D	E	F	G	H	I	L	M
QFL012	12 - 16	18	43	55	18	29	4,5	9	5,5	10	5,4	10
QFL020	20	22	55	70	22	36	5,5	10	6,6	10	5,4	12
QFL025	25	26	60	76	26	40	5,5	10	6,6	10	5,4	12

MATERIALE: ACCIAIO
MATERIAL: STEEL

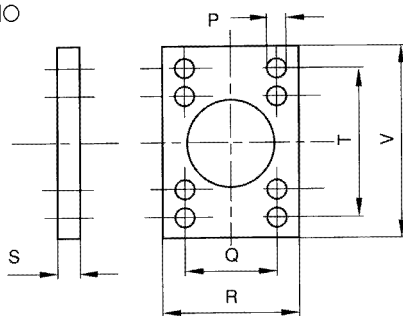

VFL

FLANGIA - FLANGE

Codice Code	Ø mm.	P	Q	S	R	T	V
VFL032	32	7	32	10	45	64	80
VFL040	40	9	36	10	52	72	90
VFL050	50	9	45	12	65	90	110
VFL063	63	9	50	12	75	100	120
VFL080	80	12	63	16	95	126	150
VFL100	100	14	75	16	115	150	170

MATERIALE: ACCIAIO
MATERIAL: STEEL

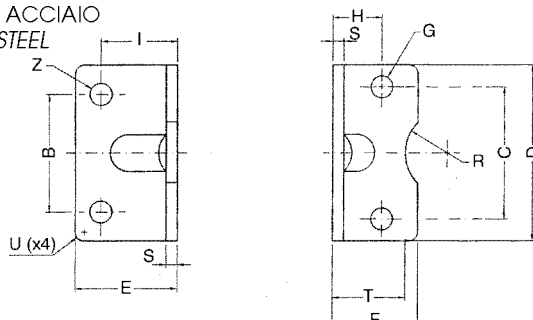

QCP

PIEDINO BASSO- LOW-RISE PEDESTAL

Codice Code	Ø mm.	C	B	D	E	F	G	H	I	S	T	R	U	Z
QCP012	12 - 16	18	18	30	17,5	17,5	4,4	13	13	3	15	9	2	5,5
QCP020	20	22	22	36	22	22	5,4	16	16	4	17	10	2	6,6
QCP025	25	26	26	40	22	23	5,4	17	16	4	19	11	2	6,6

MATERIALE: ACCIAIO
MATERIAL: STEEL

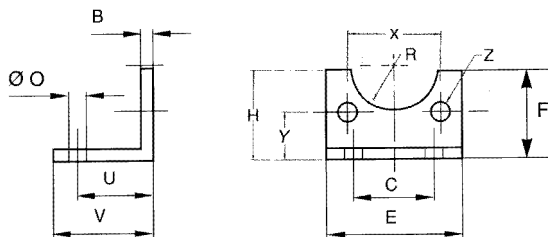

VCP

PIEDINO BASSO - LOW - RISE PEDESTAL

Codice Code	Ø mm.	B	C	E	F	O	U	V	R	Z	X	Y	H
VCP032	32	4	32	45	30	7	24	35	15	7	32.5	15.75	32
VCP040	40	4	36	52	30	10	28	36	17.5	7	38	17	36
VCP050	50	5	45	65	36	10	32	47	20	9	46.5	21.75	45
VCP063	63	5	50	75	35	10	32	45	22.5	9	56.5	21.75	50
VCP080	80	6	63	95	47	12	41	55	22.5	11	72	27	63
VCP100	100	6	75	115	53	14.5	41	57	27.5	11	89	26.5	71

MATERIALE: ALLUMINIO
MATERIAL: ALUMINIUM

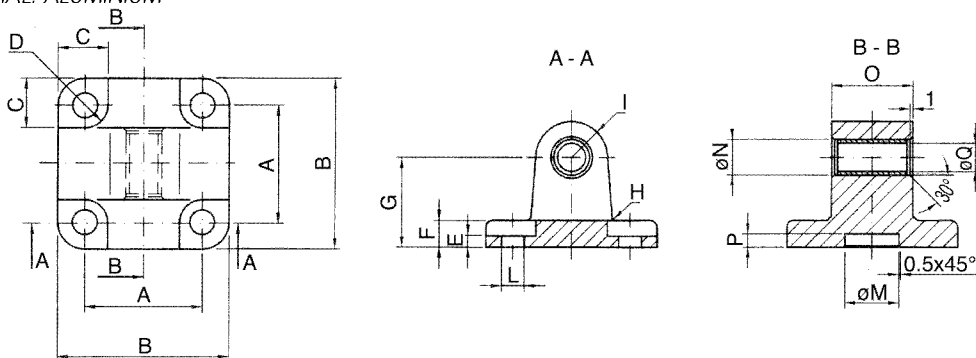

QC

CERNIERA MASCHIO CON BOCCOLE AUTOLUBRIFICANTI - MALE HINGE WITH SELF-LUBRICATING BUSHES

Codice Code	Ø mm.	A	B	C	D	E	F	G	H	I	L	M	N	O	P	Q
QCM012	12 - 16	18	27	10	4.5	2.6	6	16	2	6	4.5	10	8	12	3	6
QCM020	20	22	34	11	5	2.6	6	20	2	8	5.5	12	10	16	3	8
QCM025	25	26	38	11	5	2.6	6	20	2	8	5.5	12	10	16	3	8

MATERIALE: ALLUMINIO
MATERIAL: ALUMINIUM

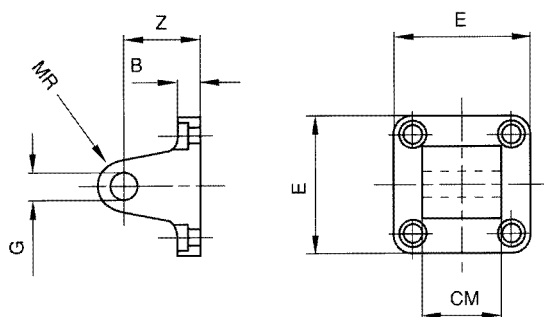

VCM

CERNIERA MASCHIO - MALE CLEVIS BRACKET

Codice Code	Ø mm.	B	E	G	Z	CM	MR
VCM032	32	9	45	10	22	26	10
VCM040	40	9	52	12	25	28	12
VCM050	50	11	65	12	27	32	12
VCM063	63	11	75	16	32	40	16
VCM080	80	14	95	16	36	50	16
VCM100	100	14	115	20	41	60	20

MATERIALE: ALLUMINIO
MATERIAL: ALUMINIUM

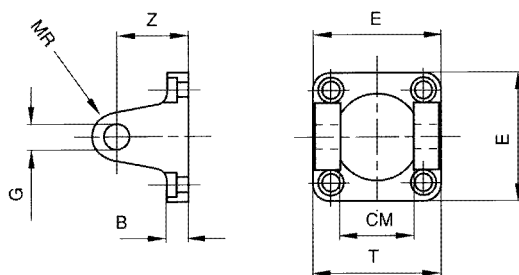

VCF

CERNIERA FEMMINA CON BOCCOLE AUTOLUBRIFICANTI - FEMALE CLEVIS BRACKET SELF-LUBRICATING

Codice Code	Ø mm.	B	E	G	T	Z	CM	MR
VCF032	32	9	45	10	45	22	26	10
VCF040	40	9	52	12	52	25	28	12
VCF050	50	11	65	12	60	27	32	12
VCF063	63	11	75	16	70	32	40	16
VCF080	80	14	95	16	90	36	50	16
VCF100	100	14	115	20	110	41	60	20

MATERIALE: ALLUMINIO
MATERIAL: ALUMINIUM

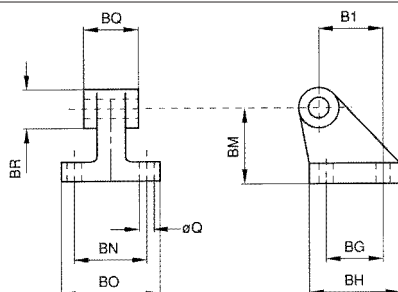

VAS

ARTICOLAZIONE A SQUADRA - SQUARE JOINT

Codice Code	Ø mm.	Q	BG	BH	B1	BM	BN	BO	BQ	BR
VAS032	32	6.6	18	31	21	32	38	51	26	20
VAS040	40	6.6	22	35	24	36	41	54	28	22
VAS050	50	9	30	45	33	45	50	65	32	26
VAS063	63	9	35	50	37	50	52	67	40	30
VAS080	80	11	40	60	47	63	66	86	50	30
VAS100	100	11	50	70	55	71	76	96	60	38

MATERIALE: ACCIAIO
MATERIAL: STEEL

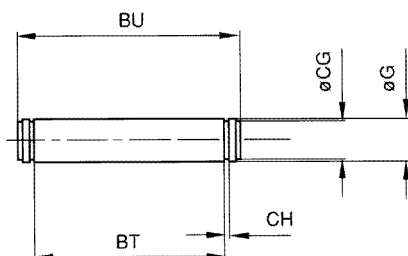

VPE

PERNO PER CERNIERA CON SEEGER - PIN WITH SEEGER

Codice Code	Ø mm.	G	BT	BU	CG	CH
VPE032	32	10	46	53	9.6	1.1
VPE040	40	12	53	60	11.5	1.1
VPE050	50	12	61	68	11.5	1.1
VPE063	63	16	71	78	15.2	1.1
VPE080	80	16	91	98	15.2	1.1
VPE100	100	20	111	118	19	1.3

MATERIALE: ACCIAIO
MATERIAL: STEEL

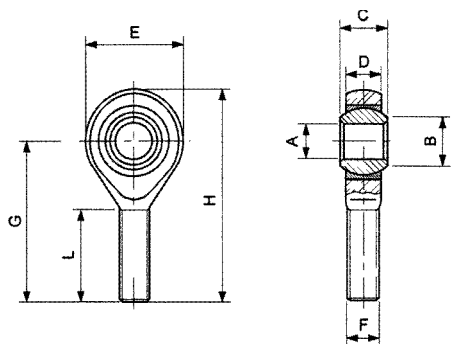

TM

TESTA DI BIELLA MASCHIO - MALE ROD ENDS

Codice Code	F	A	B	C	Ø	D	E	G	H	L	CARICO RADIALE		PESO
											DINAMICO	STATICO	
TM020	M5x0.8	5	7.5	8	11.11	7.5	18	33	42	19	430	1000	13
TM032	M6x1	6	8.9	9	12.7	7.5	20	36	46	21	470	1100	15
TM050	M8x1.25	8	10.4	12	15.88	9.5	24	42	54	25	780	1900	34
TM080	M10x1.5	10	12.9	14	19.05	11.5	30	48	63	28	1200	3100	70
TM100	M12x1.75	12	15.4	16	22.23	12.5	34	54	71	32	1400	3700	110